

CAD FILE :

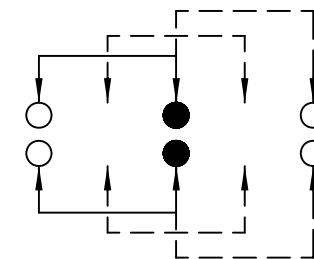

**SCHEMATIC (NON-SHORTING)**

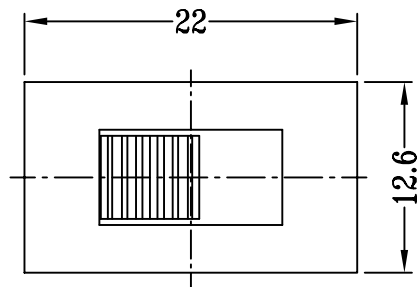
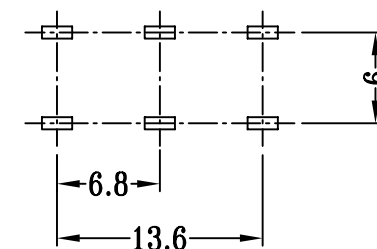
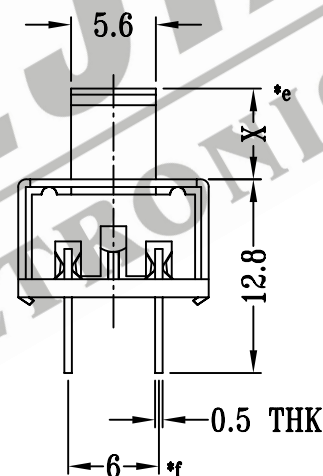
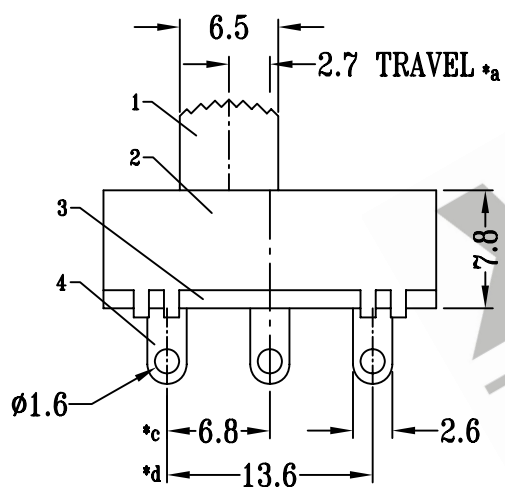

**P.C.B LAYOUT**

注:带"\*"表示关键尺寸(6个)

8	POSITION PLATE	STEEL STRIP	1	Ni PLATED	TOLERANCE UNLESS SPECIFIED	SHENZHEN XIEJIA ELECTRONICS CO.,LTD.				
7	STEEL BALL	STEEL	1	NATURAL						
6	SPRING	STEEL WIRE	1	TEMPER	WITHIN: 1.5±0.1mm OVER : 1.5±0.2mm	ISSUE	DATE	DESCRIPTIONS		APPD
5	CONTACT (CLIP)	PBS STRIP	2	Ag PLATED						
4	TERMINAL	BRASS STRIP	6	Ag PLATED OVER Ni PLATED	TITLE: VERTICAL SLIDE SWITCH		UNIT : M M	DRWG NO : XJ-DR-SS3E26-00		
3	TERMINAL BASE	PHENOLIC RESIN	1	BLACK	MODEL: SS-23E26		SCALE : 2:1	DWN.	ZHOUYU	2005-12-31
2	FRAME	STEEL STRIP	1	Zn PLATED				CHK'D	FANGYING	2005-12-31
1	KNOB	PC	1	BLACK	ALL MATERIALS MUST BE COMPLIANT TO ROHS		APPD.	KANGXINAN	2005-12-31	
NO.	PART NAME	MATERIAL	QTY.	FINISHING						